

PODIUM ELEVATION
基座立面圖

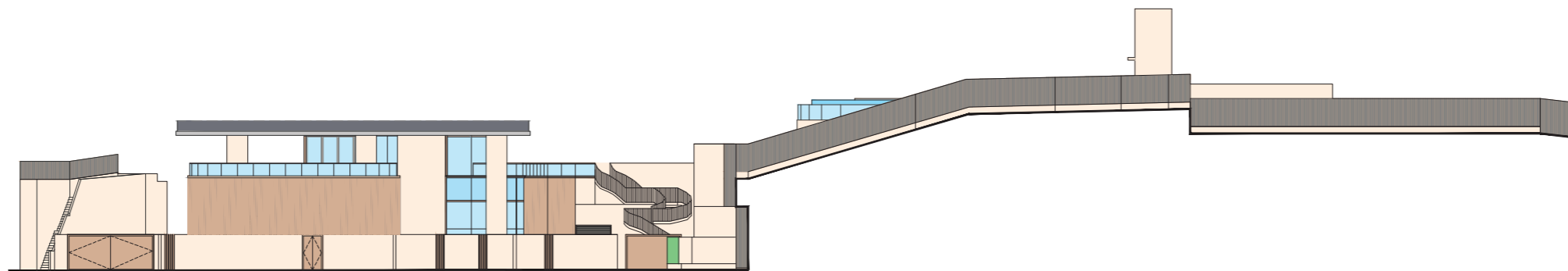
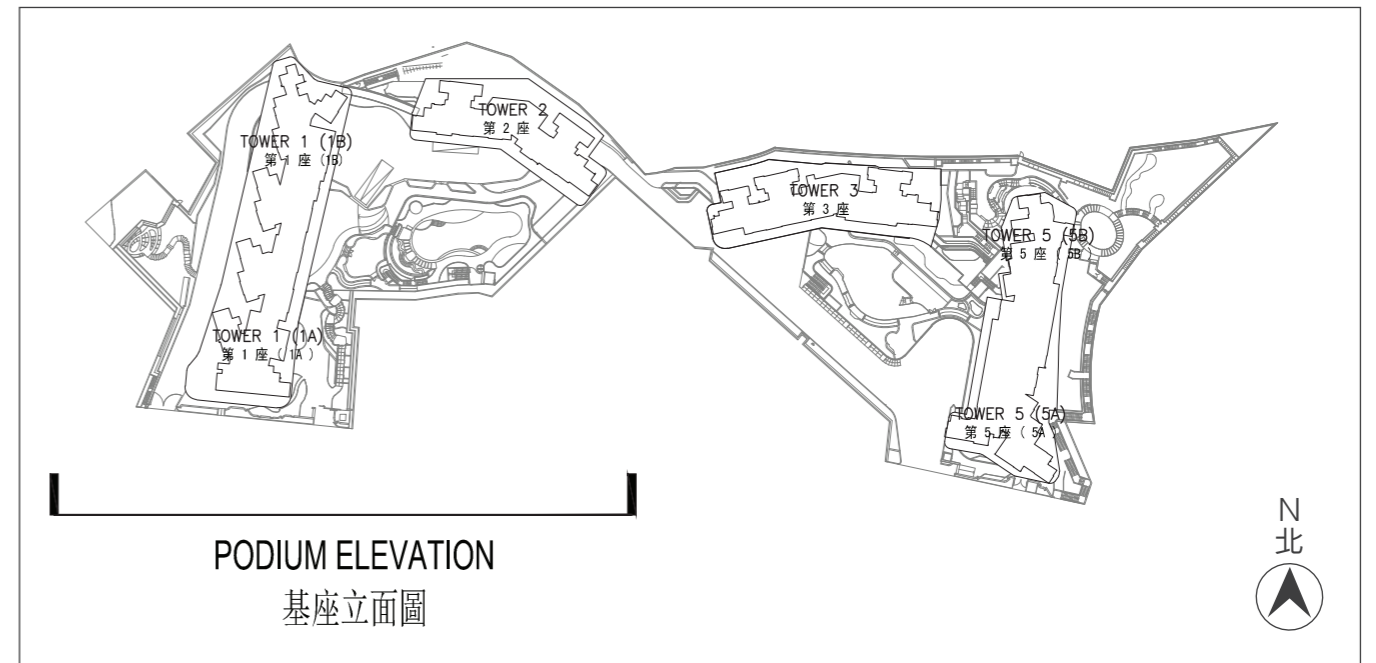

The Authorized Person for the Phase has certified that the elevations shown on these plans:
 1. are prepared on the basis of the approved building plans for the Phase as of 24 September 2024; and
 2. are in general accordance with the outward appearance of the Phase.

期數的認可人士已證明本圖所顯示的立面：
 1. 以2024年9月24日的情況為準的期數經批准的建築圖則為基礎擬備；及
 2. 大致上與該期數的外觀一致。

ELEVATION A (TOWER 1 (1A & 1B))
立面圖 A (第1座 (1A 及 1B))

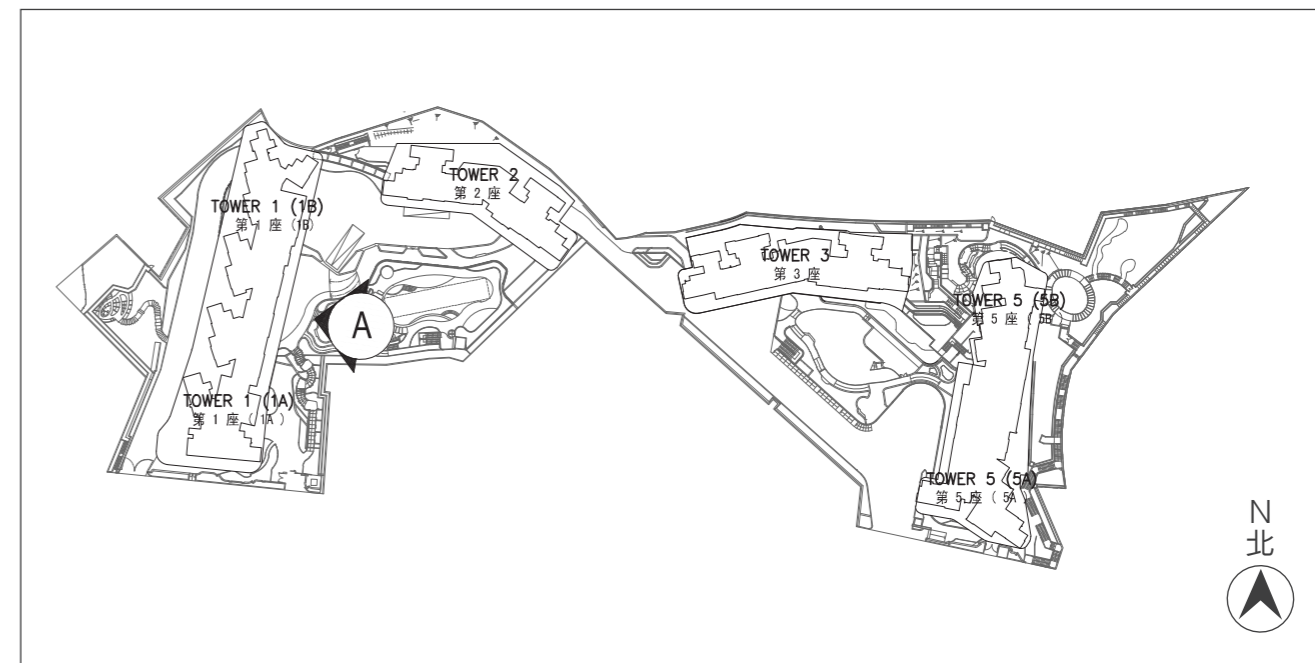
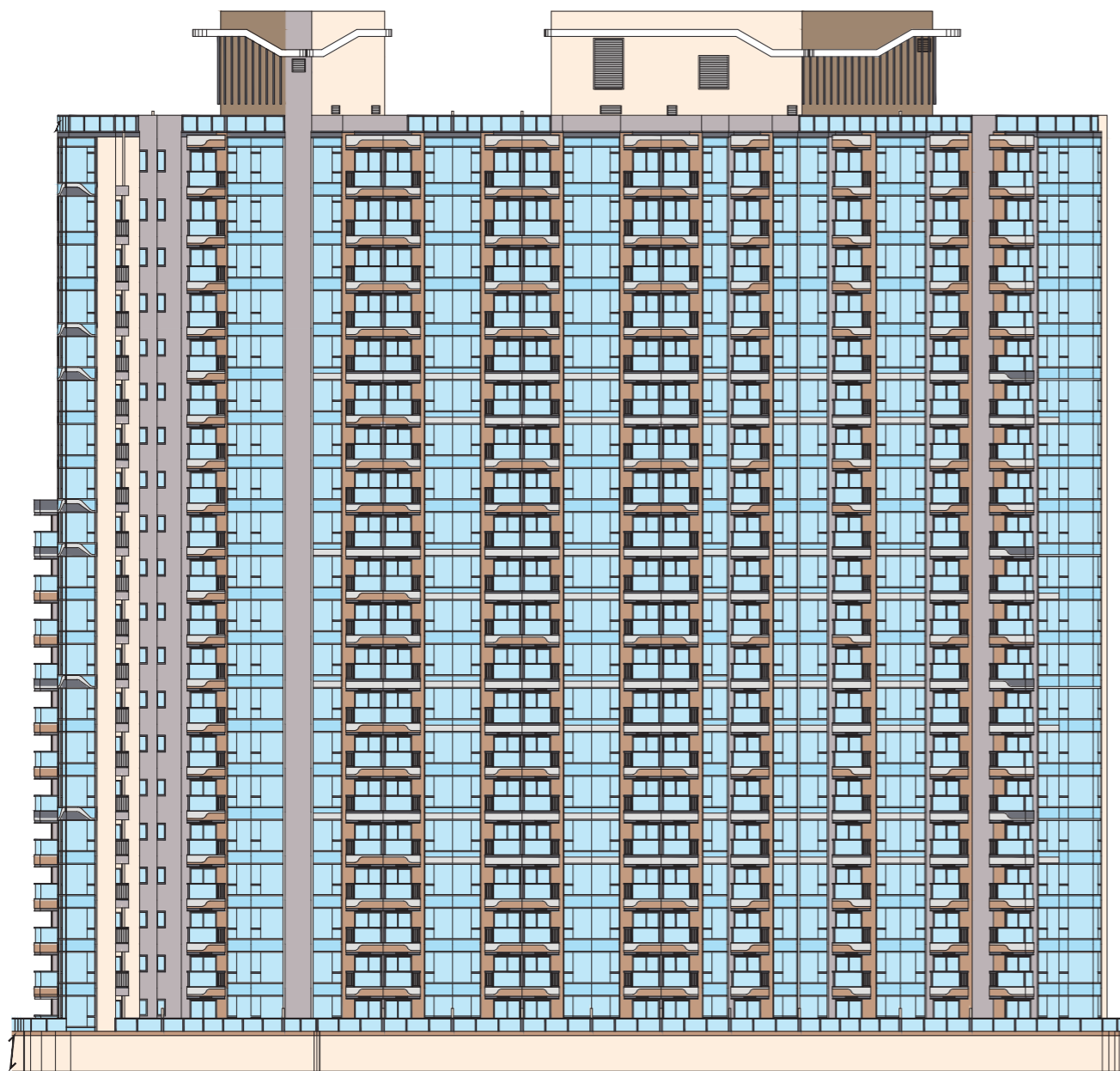

The Authorized Person for the Phase has certified that the elevations shown on these plans:
1. are prepared on the basis of the approved building plans for the Phase as of 24 September 2024; and
2. are in general accordance with the outward appearance of the Phase.

Note: 4/F, 13/F, 14/F and 24/F are omitted.

期數的認可人士已證明本圖所顯示的立面：
1. 以2024年9月24日的情況為準的期數批准的建築圖則為基礎擬備；及
2. 大致上與期數的外觀一致。

備註：不設4樓、13樓、14樓及24樓。

ELEVATION B (TOWER 1 (1A & 1B))
立面圖 B (第1座 (1A 及 1B))

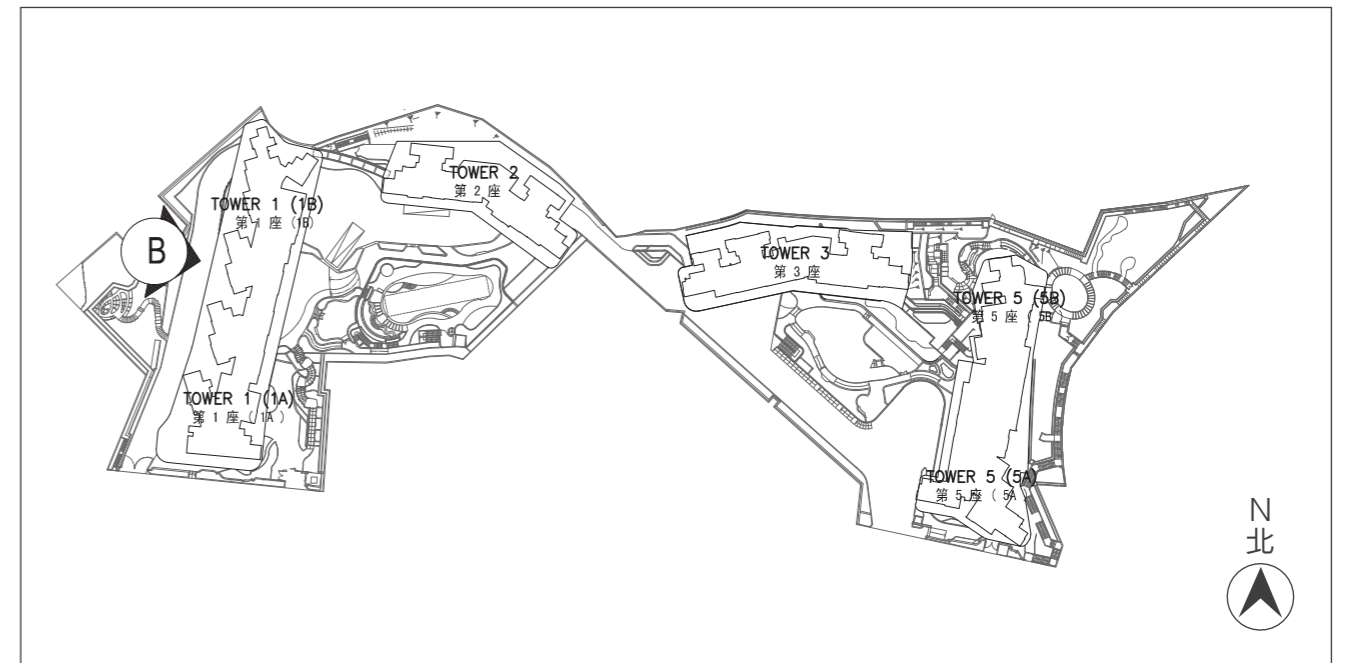

The Authorized Person for the Phase has certified that the elevations shown on these plans:
1. are prepared on the basis of the approved building plans for the Phase as of 24 September 2024; and
2. are in general accordance with the outward appearance of the Phase.

Note: 4/F, 13/F, 14/F and 24/F are omitted.

期數的認可人士已證明本圖所顯示的立面：

1. 以2024年9月24日的情況為準的期數批准的建築圖則為基礎擬備；及
2. 大致上與期數的外觀一致。

備註：不設4樓、13樓、14樓及24樓。

ELEVATION C (TOWER 1 (1A & 1B))
立面圖 C (第1座 (1A 及 1B))

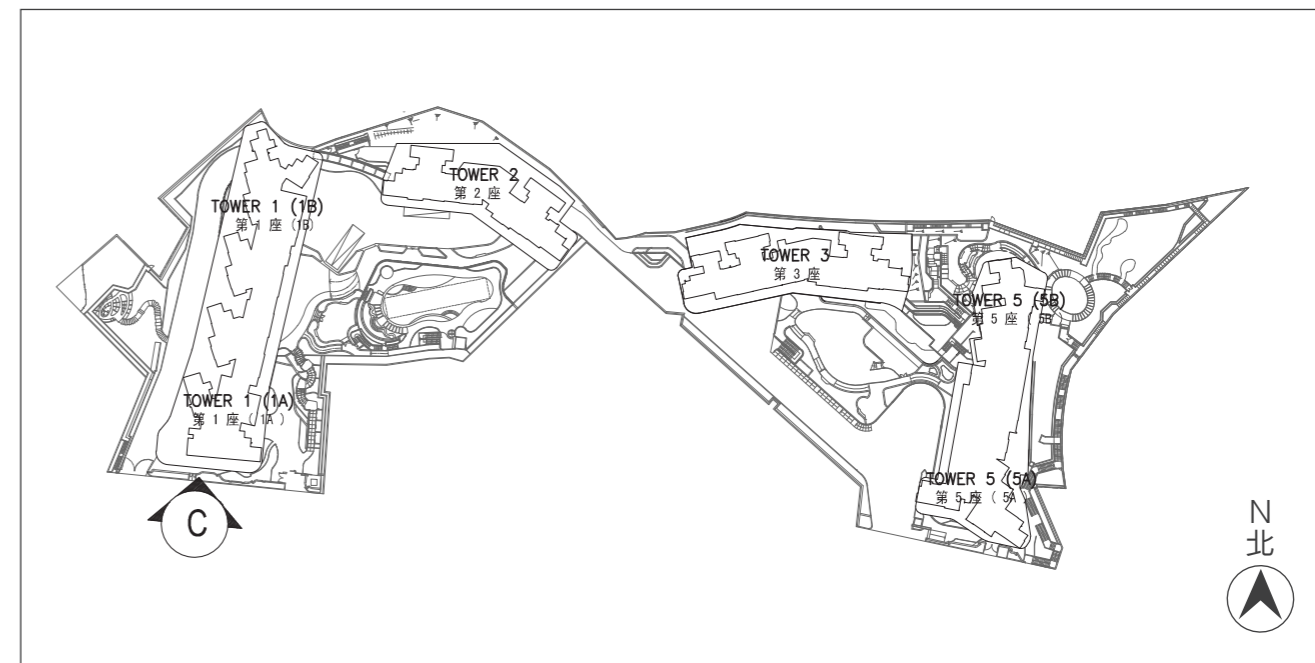
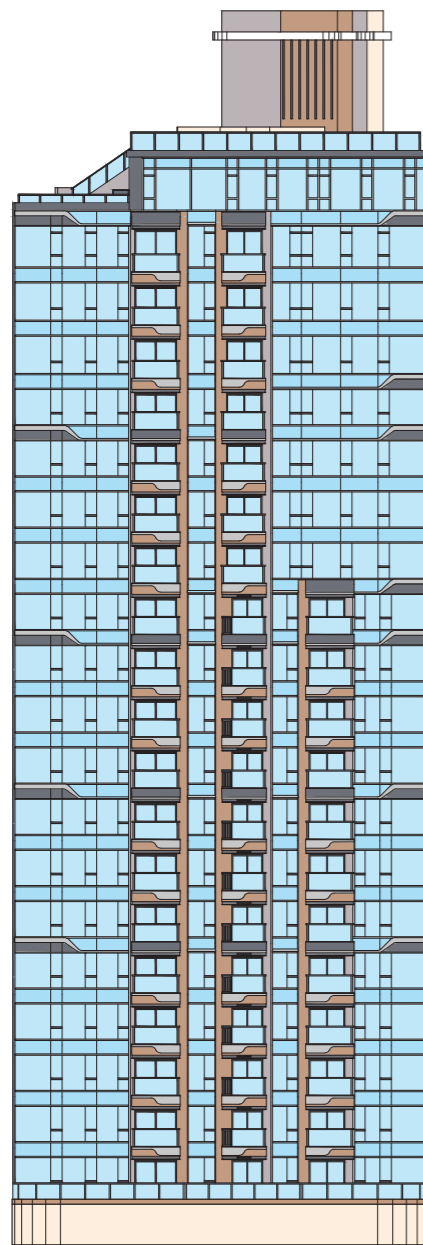

The Authorized Person for the Phase has certified that the elevations shown on these plans:
1. are prepared on the basis of the approved building plans for the Phase as of 24 September 2024; and
2. are in general accordance with the outward appearance of the Phase.

Note: 4/F, 13/F, 14/F and 24/F are omitted.

期數的認可人士已證明本圖所顯示的立面：
1. 以2024年9月24日的情況為準的期數批准的建築圖則為基礎擬備；及
2. 大致上與期數的外觀一致。

備註：不設4樓、13樓、14樓及24樓。

ELEVATION D (TOWER 1 (1A & 1B))
立面圖 D (第1座 (1A 及 1B))

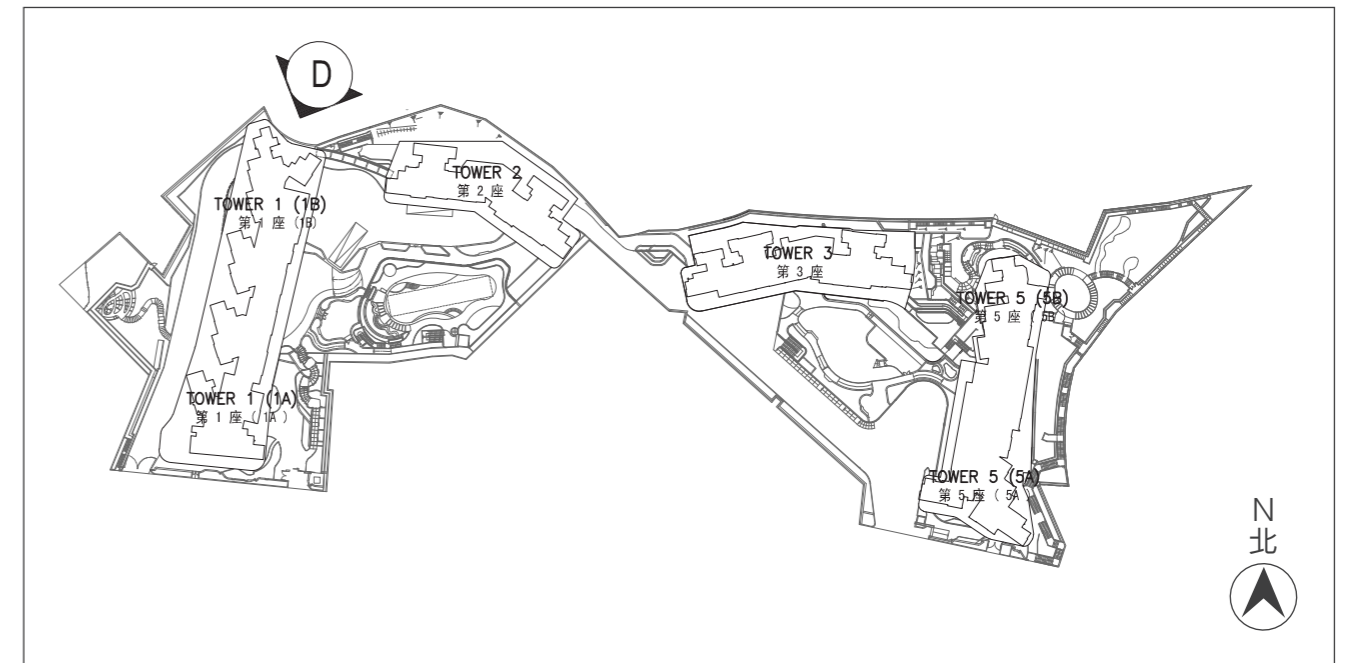
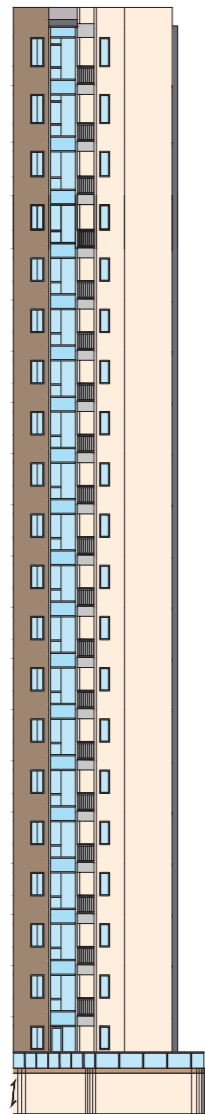

The Authorized Person for the Phase has certified that the elevations shown on these plans:
1. are prepared on the basis of the approved building plans for the Phase as of 24 September 2024; and
2. are in general accordance with the outward appearance of the Phase.

Note: 4/F, 13/F, 14/F and 24/F are omitted.

期數的認可人士已證明本圖所顯示的立面：

1. 以2024年9月24日的情況為準的期數批准的建築圖則為基礎擬備；及
2. 大致上與期數的外觀一致。

備註：不設4樓、13樓、14樓及24樓。

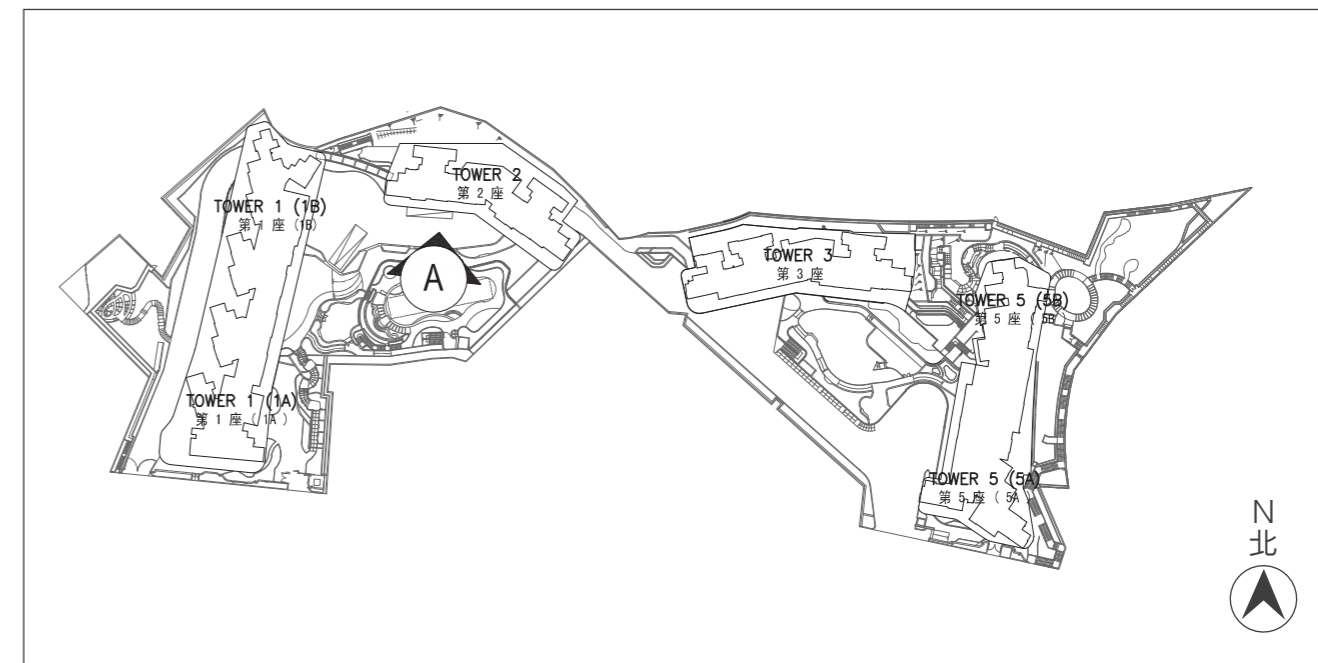
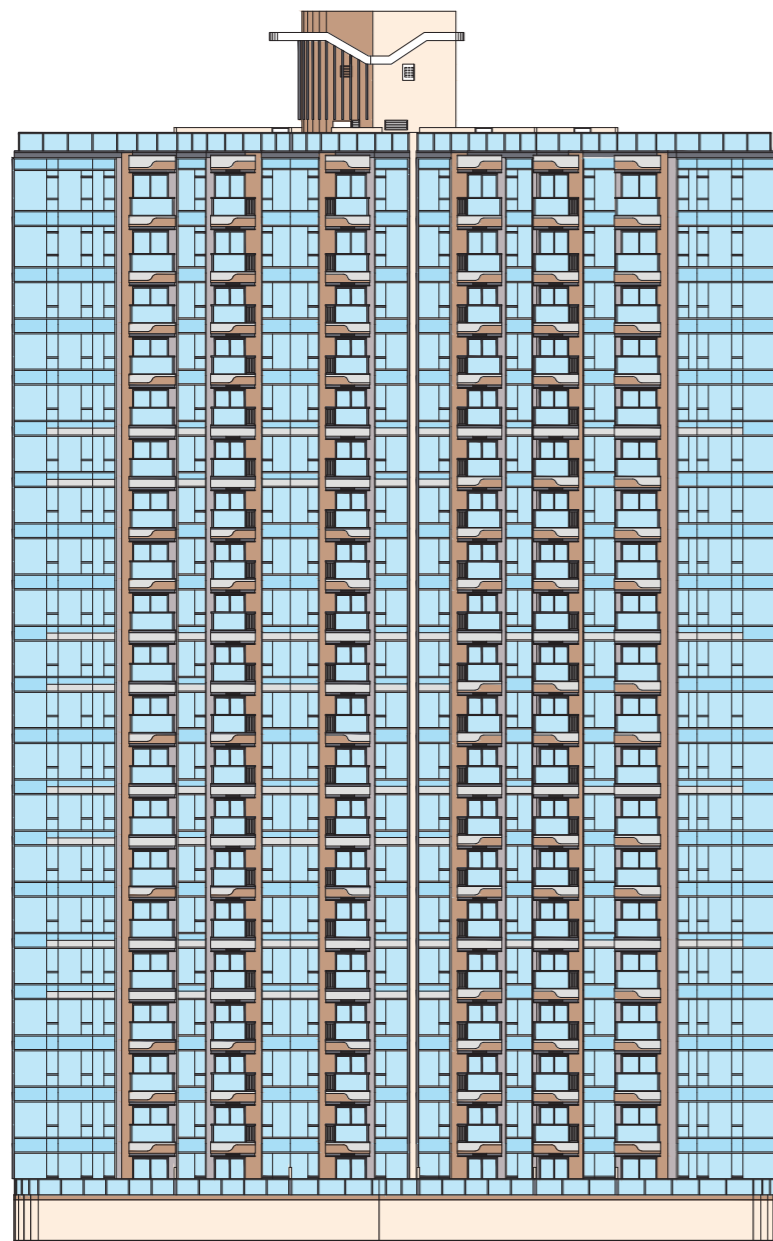
ELEVATION A (TOWER 2)
立面圖 A (第 2 座)

The Authorized Person for the Phase has certified that the elevations shown on these plans:

1. are prepared on the basis of the approved building plans for the Phase as of 24 September 2024; and
2. are in general accordance with the outward appearance of the Phase.

Note: 4/F, 13/F, 14/F and 24/F are omitted.

期數的認可人士已證明本圖所顯示的立面：

1. 以2024年9月24日的情況為準的期數批准的建築圖則為基礎擬備；及
2. 大致上與期數的外觀一致。

備註：不設4樓、13樓、14樓及24樓。

ELEVATION B (TOWER 2)
立面圖 B (第2座)

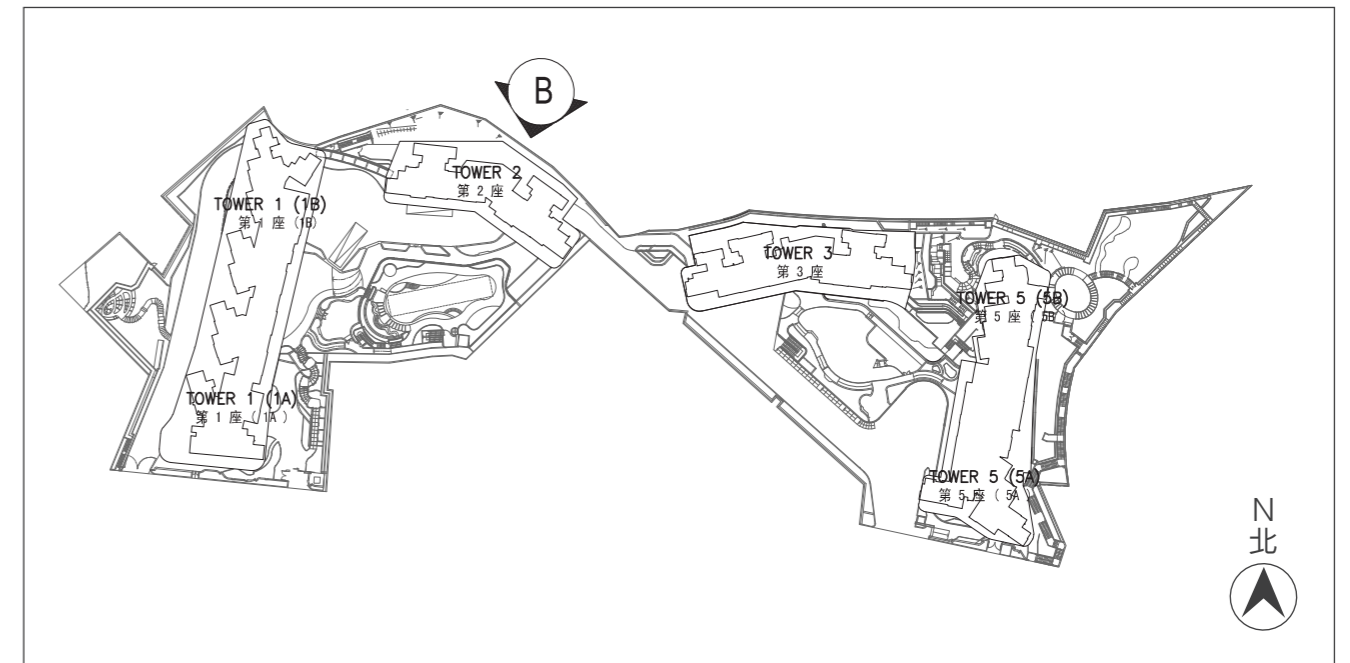
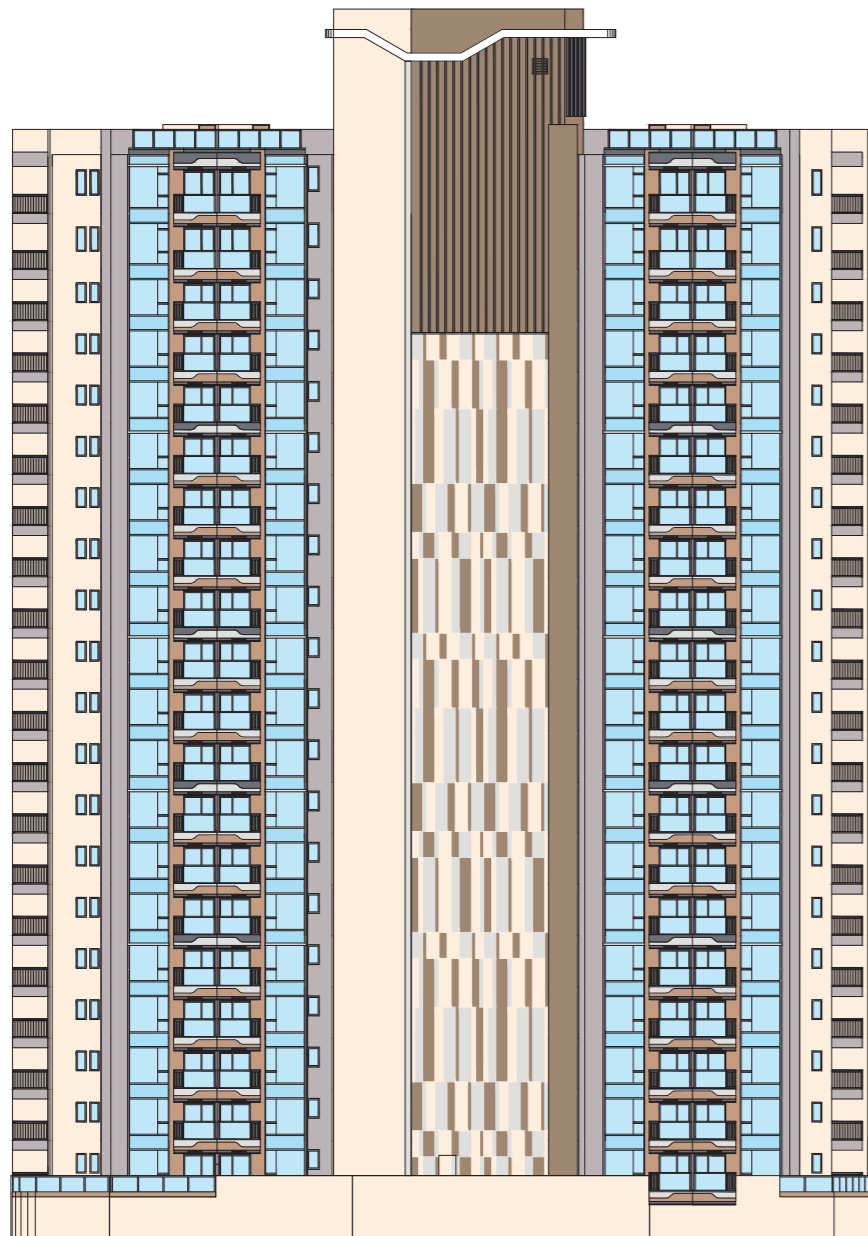

The Authorized Person for the Phase has certified that the elevations shown on these plans:
1. are prepared on the basis of the approved building plans for the Phase as of 24 September 2024; and
2. are in general accordance with the outward appearance of the Phase.

Note: 4/F, 13/F, 14/F and 24/F are omitted.

期數的認可人士已證明本圖所顯示的立面：

1. 以2024年9月24日的情況為準的期數批准的建築圖則為基礎擬備；及
2. 大致上與期數的外觀一致。

備註：不設4樓、13樓、14樓及24樓。

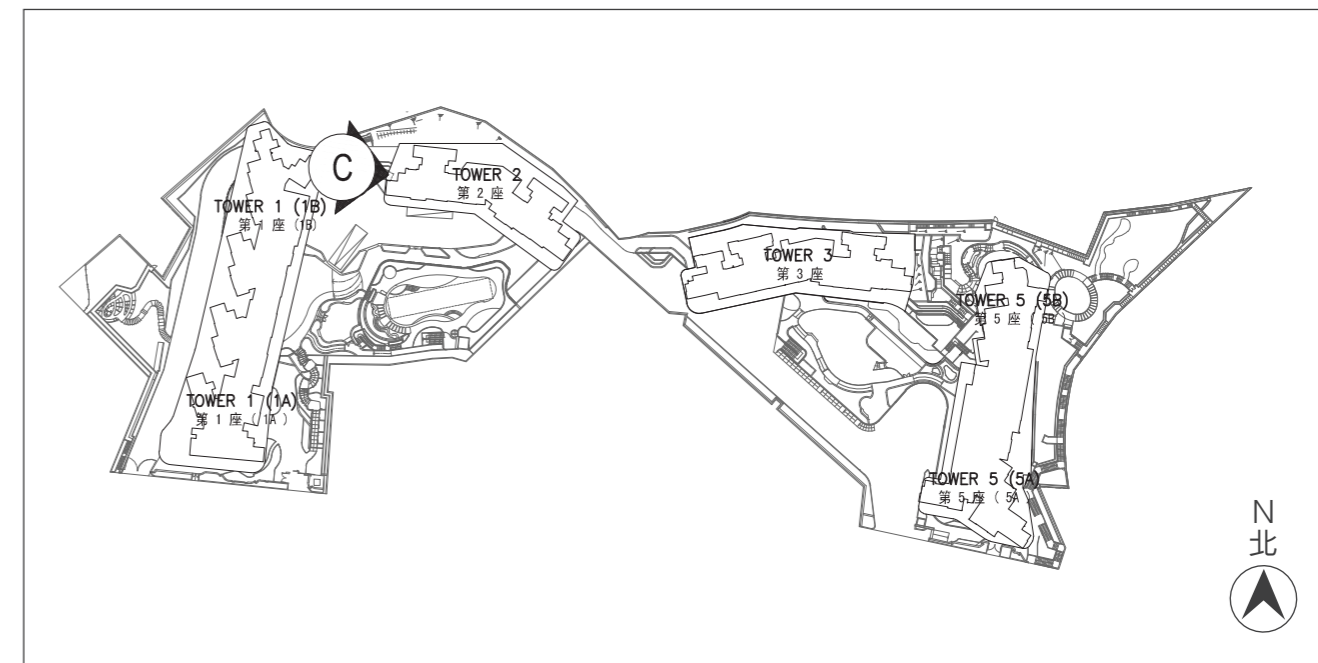
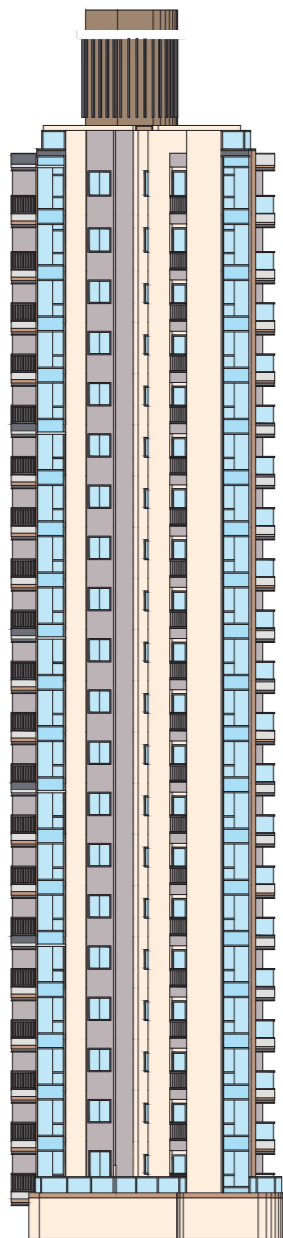
ELEVATION C (TOWER 2)
立面圖 C (第 2 座)

The Authorized Person for the Phase has certified that the elevations shown on these plans:

1. are prepared on the basis of the approved building plans for the Phase as of 24 September 2024; and
2. are in general accordance with the outward appearance of the Phase.

Note: 4/F, 13/F, 14/F and 24/F are omitted.

期數的認可人士已證明本圖所顯示的立面：

1. 以 2024 年 9 月 24 日的情況為準的期數批准的建築圖則為基礎擬備；及
2. 大致上與期數的外觀一致。

備註：不設 4 樓、13 樓、14 樓及 24 樓。

ELEVATION D (TOWER 2)
立面圖 D (第 2 座)

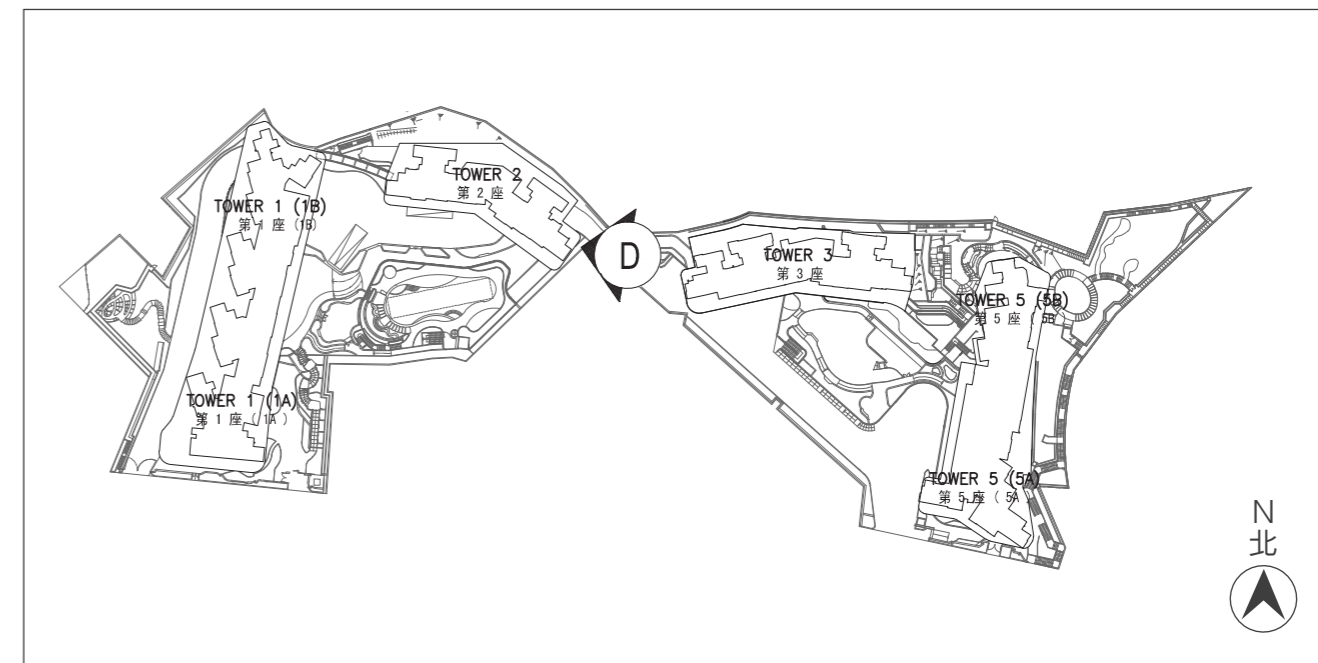

The Authorized Person for the Phase has certified that the elevations shown on these plans:
1. are prepared on the basis of the approved building plans for the Phase as of 24 September 2024; and
2. are in general accordance with the outward appearance of the Phase.

Note: 4/F, 13/F, 14/F and 24/F are omitted.

期數的認可人士已證明本圖所顯示的立面：
1. 以 2024 年 9 月 24 日的情況為準的期數批准的建築圖則為基礎擬備；及
2. 大致上與期數的外觀一致。

備註：不設 4 樓、13 樓、14 樓及 24 樓。